

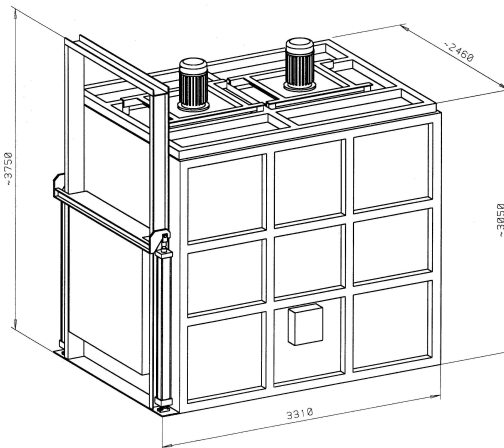

CHAMBER TYPE FURNACES WITH CONVECTIVE OPERATION

AL HOMOGENIZING FURNACE

| | | | |
|--------------------------------|-----------------------|--------------------------------------|------------------|
| Furnace stock: | Al castings | Nominal heating capacity: | 80 kW electrical |
| Max. weight of stock: | 1,6 t | Max. temperature of working chamber: | 550 °C |
| Moving of furnace stock: | charging of fork lift | Temperature accuracy: | ± 3 °C |
| Dimensions of working chamber: | 2500x1500x1600 mm | | |



CORE DRYING FURNACE

| | | | |
|--------------------------------|------------------|--------------------------------------|--------------------|
| Furnace stock: | Al castings | Nominal heating capacity: | 500 kW natural gas |
| Max. weight of furnace stock: | 2000 kg | Max. temperature of working chamber: | 500 °C |
| Dimensions of working chamber: | 1200x800x1600 mm | | |

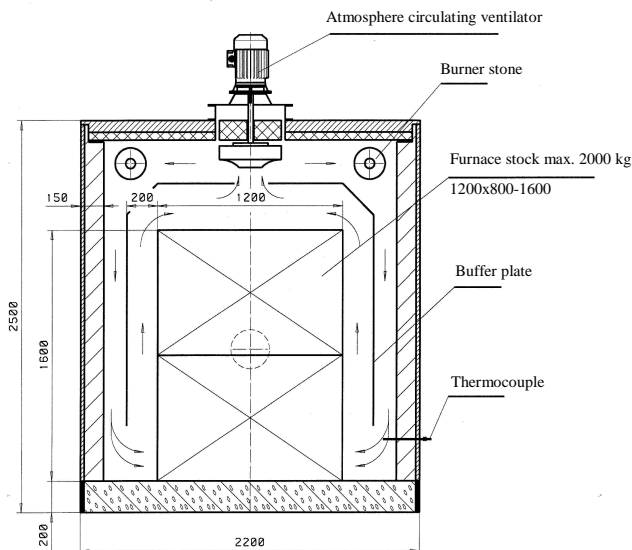

**TÜKI Research and Development Company for
Combustion Technology**

3515 Miskolc-Egyetemváros Pf. 3
Phone: (36/46) 555-070, Fax: (36/46) 555-078

