

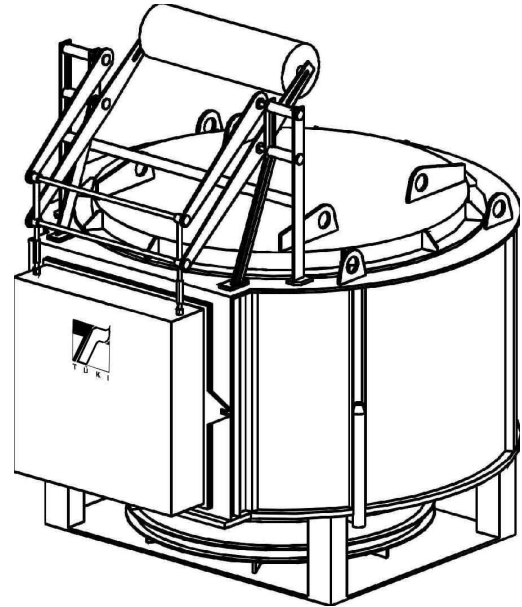

OTHER TYPE OF FOUNDRY FURNACES

ROTARY HEARTH FURNACES FOR FOUNDRIES

Furnace stock:	ceramic moulds
Max. weight of furnace stock:	120 kg
Moving of furnace stock:	manually
Dimension of working chamber:	Ø1800x790 mm
Nominal heating capacity:	200 kW natural gas
Max. temperature of working chamber:	1000 °C



CHAMBER TYPE CERAMIC FURNACE

Furnace stock:	ceramic moulds	Nominal heating capacity:	450 kW natural gas
Max. weight of furnace stock:	1000 kg	Max. temperature of working chamber:	1200 °C
Dimension of working chamber:	1835x1720 mm	Flue gas treatment:	application of recuperator and after-burning facility

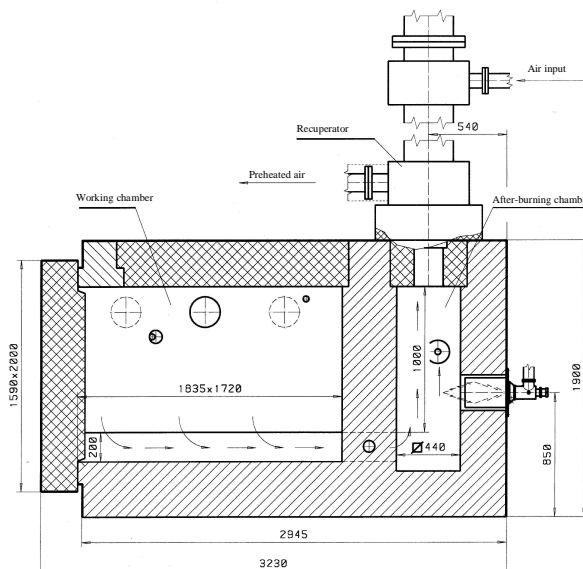

TÜKI Research and Development Company for Combustion Technology

3515 Miskolc-Egyetemváros Pf. 3
Phone: (36/46) 555-070, Fax: (36/46) 555-078

