

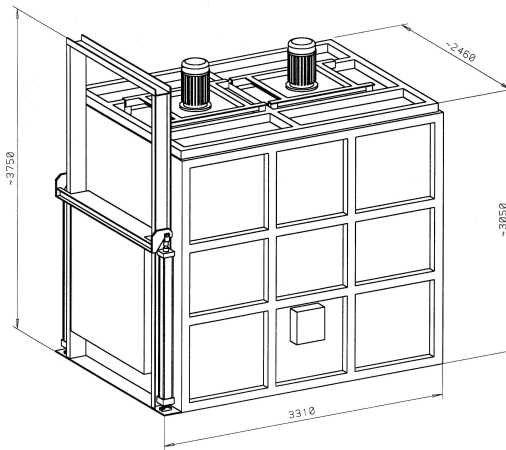

## ALUMINIUM HEAT TREATING FURNACE

### AL HOMOGENIZING FURNACE

Furnace stock:	Al castings	Nominal heating capacity:	80 kW electrical
Max. weight of furnace stock:	1,6 t	Max. temperature of furnace chamber:	550 °C
Moving of furnace stock:	charging of fork lift	Temperature accuracy:	± 3 °C
Dimensions of working chamber:	2500x1500x1600 mm		



### BOGIE TYPE ALUMINIUM ANNEALING FURNACE

Furnace stock:	Al castings	Nominal heating capacity:	120 kW electrical
Max. weight of furnace stock:	6 t	Max. temperature of working chamber:	150-200 °C
Moving of furnace stock:	by two stage bogie	Temperature of accuracy:	± 3 °C
Dimensions of working chamber:	2300x4500x1600 mm		

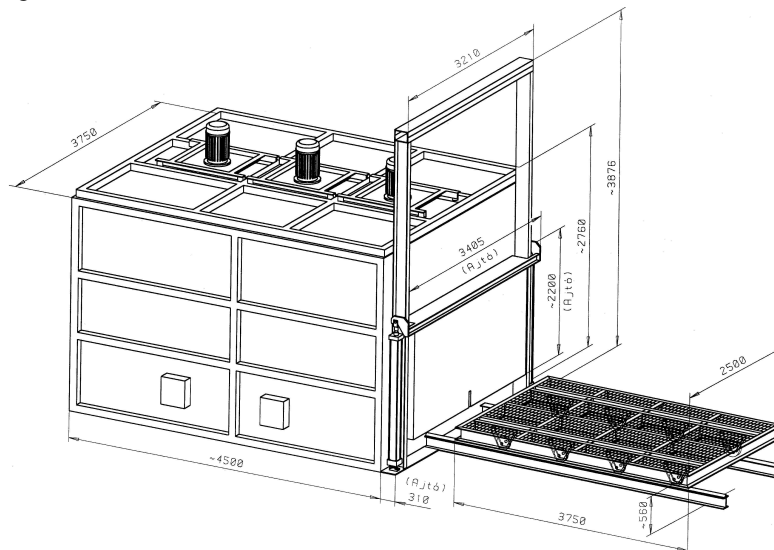

## TÜKI Research and Development Company for Combustion Technology

3515 Miskolc-Egyetemváros Pf. 3  
Phone: (36/46) 555-070, Fax: (36/46) 555-078

